

A

B

C

D

E

F

Revision

Rev	Description	Drawn	Approved	Date
△△	Ø3.10 → Ø3.25	DJKim	Song	20250417

1

1

2

2

3

3

4

4

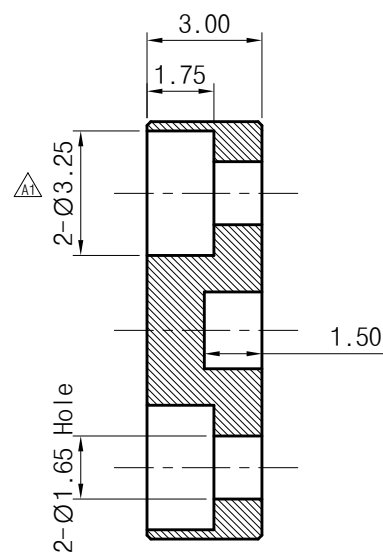
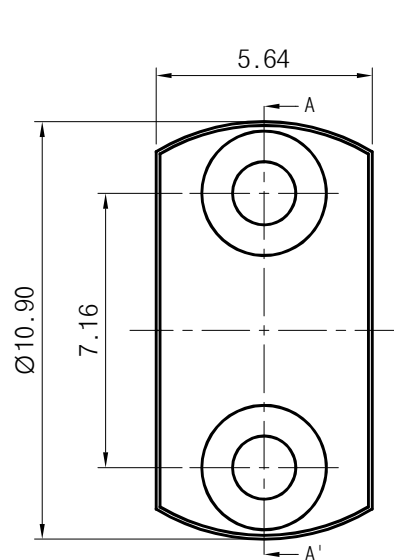

<Section A-A'>

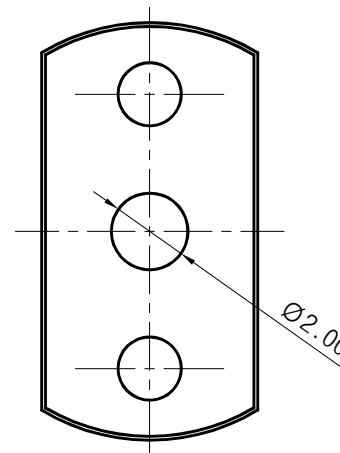

[Note]

1. Material: Stainless Steel(STS 303)
2. Surface
 - 1) Plating : Passivated
3. Appearance
 - 1) surface roughness(In case of no direction)
 - Inner : under 1.6a
 - Outer : under 6.3a
 - 2) No burr and scratch on surface
 - 3) Tolerance of edge chamfer
 - Inner : under 0.03mm
 - Outer : under 0.1mm
4. All dimensions are only for cutting material (not including plating thickness)
8. RoHS requirement

THE INFORMATION HEREON/HEREIN IS PROPRIETARY TO WITH-WAVE CO., LTD. IT SHALL NOT BE COUPIED, DISCLOSED OR USED(PARTIALLY OR WHOLLY) IN ANY MANNER WITHOUT PRIOR EXPRESSED WRITTEN AUTHORIZATION OF WITH-WAVE CO., LTD.

Tolerances	0	±0.1	±2.0°	concentricity	○	±0.05	Approved	Song	Date	2020. 12. 10
	0.X	±0.05	±1.0°		○	±0.05	Checked	Sun	Name	Body
	0.XX	±0.03		tolerances	○	±0.05	Drawn	Teri K	No.	WB0642F03
	Scale	N/A	unit		mm	Third Angle projection	⊕			

A

B

C

D

E

F