

<Specification>

1. Material
  - 1) Connector : 2.4mm Female(Stainless Steel)
  - 2) Cable : WT200 Cable
  - 3) Adhesive Shrink Tube(Black)
  - 4) Marking tube(white)
2. Electrical
  - 1) Impedance : 50Ω
  - 2) Frequency range : DC to 50GHz
  - 3) VSWR : 1.3 : 1(DC to 50GHz)  
Assembly to be 100% tested for Return loss and Insertion loss.
  - 4) Withstanding Voltage : 500Vrms max.  
Assembly to be 100% tested for Opens, Shorts & Hipot tested(AC or DC).  
The Hipot voltage for the assembly should be set to the end option with the lowest test voltage rating.
3. Mechanical
  - 1) Durability : 500 Cycles
4. Environmental
  - 1) Temp. Range : -40°C to +85°C
  - 2) RoHS Compliant
5. Cable Assembly to have protective cap assembled on each end and to be individually packaged in bag with test report.

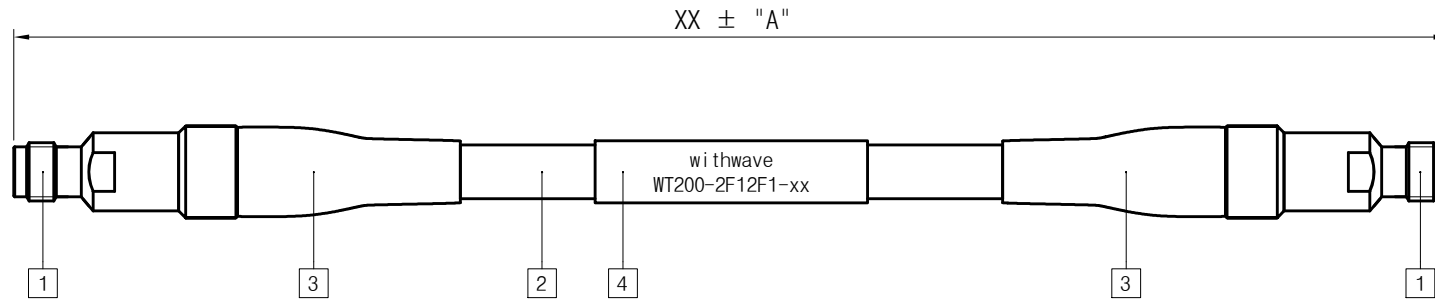

Model (Part No.)	XX (Length)	"A" (Tolerance)
WT200-2F12F1-12inch	12 inch (304.8mm)	+0.196 inch / -0 (+5.0mm / -0.0)
WT200-2F12F1-24inch	24 inch (609.6mm)	+0.393 inch / -0 (+10.0mm / -0.0)
WT200-2F12F1-36inch	36 inch (914.4mm)	+0.590 inch / -0 (+15.0mm / -0.0)
WT200-2F12F1-48inch	48 inch (1219.2mm)	+0.590 inch / -0 (+15.0mm / -0.0)

Title	WT200 Cable Assembly 2.4mm(F)-2.4mm(F) Connector
Part No.	WT200-2F12F1-xx

THE INFORMATION HEREON/HEREIN IS PROPRIETARY TO WITH-WAVE CO., LTD. IT SHALL NOT BE COUPIED, DISCLOSED OR USED(PARTIALLY OR WHOLLY) IN ANY MANNER WITHOUT PRIOR EXPRESSED WRITTEN AUTHORIZATION OF WITH-WAVE CO., LTD.	Scale	N/A	Date	2025.12.01	<b>withwave</b>	Rev.	-
	Unit	inch	Drawn	Teri K			