

<Specification>

1. Material
 1) Body : Stainless Steel (Passivated)
 2) Center Conductor : BeCu (Au Plated)
 3) Insulator : PEI

2. Electrical
 1) Impedance : 50Ω
 2) Frequency range : DC to 40GHz
 3) VSWR : 1.15 : 1 (DC to 18GHz)
 1.25 : 1 (18 to 40GHz)

- Equivalent model
 1) Southwest Microwave P/N : 1011-15SF

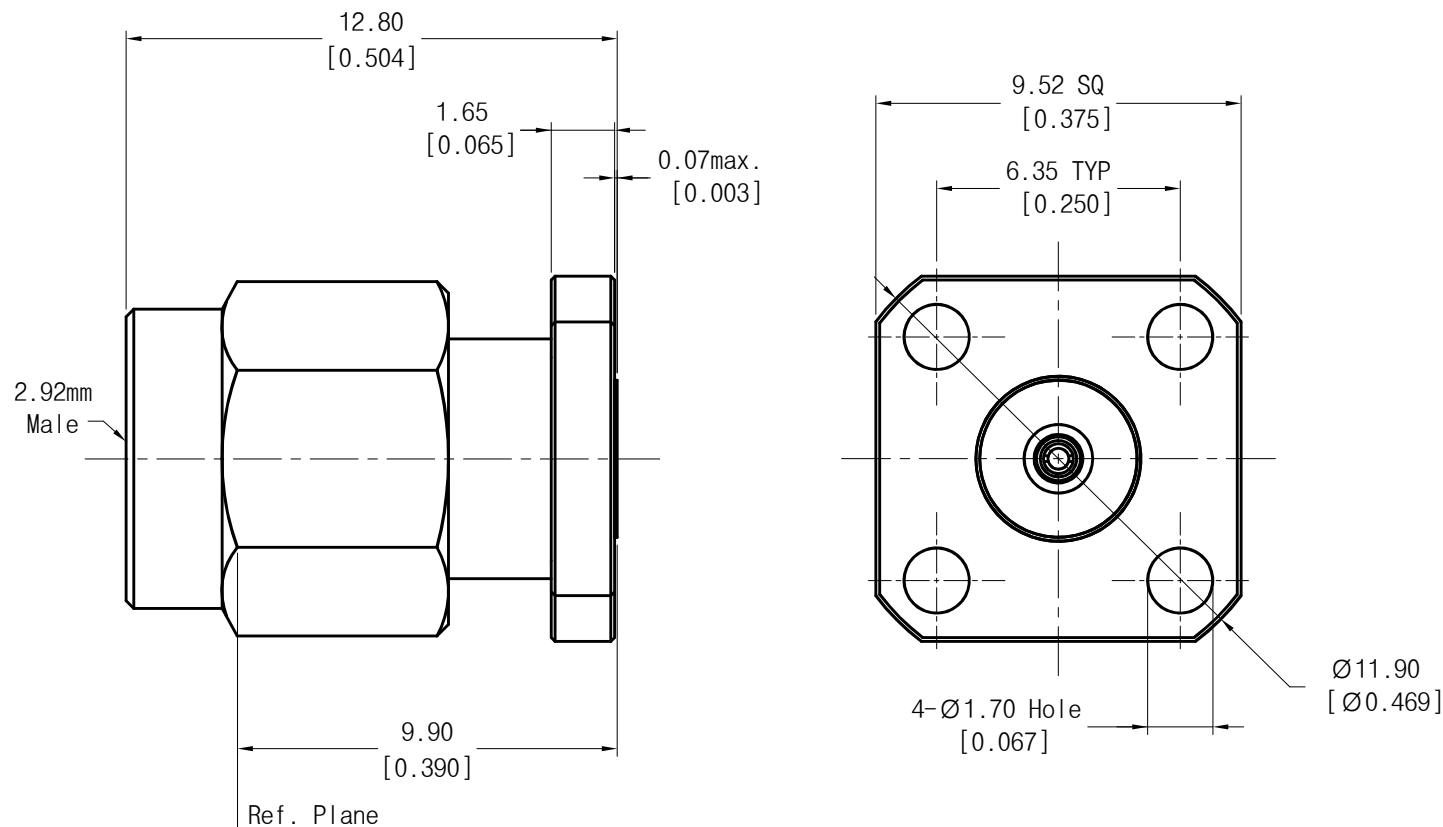

Launch Pin Diameter	Max. Pin Depth
0.503mm[0.02"]	1.6mm[0.063"]

Tolerance	Dimension	Range	Angle	Date	2015. 12. 07	Title	2.92mm(M) Panel Mount 0.375"SQ 0.020" Pin Accept Type Conn.
	0	±0.1	±2.0°	Approved	..		Part No.
	0.X	±0.05	±1.0°	Checked	.		
0.XX	±0.03		Drawn	Teri K	Rev.		
Scale		Unit	mm				

THE INFORMATION HEREON/HEREIN IS PROPRIETARY TO WITH-WAVE CO., LTD. IT SHALL NOT BE COUPIED, DISCLOSED OR USED(PARTIALLY OR WHOLLY) IN ANY MANNER WITHOUT PRIOR EXPRESSED WRITTEN AUTHORIZATION OF WITH-WAVE CO., LTD.