

<Specification>

1. Electrical
 - 1-1. Impedance : 50Ω
 - 1-2. Frequency range : DC to 110GHz
 - 1-3. VSWR : 2.0:1
2. Material
 - 2-1. Body(01) : Stainless Steel(Passivated)
Body(02) : Stainless Steel(Passivated)
Block : Stainless Steel(Passivated)
 - 2-2. Pin : BeCu(Au Plated)
 - 2-3. Insulator : Ultem1000, PTFE
3. Mechanical
 - 3-1. Durability : 500 Cycles
- ⚠ 4. Environmental
 - 1) Temp. Range : -40°C to +125°C
 - 2) RoHS Compliant

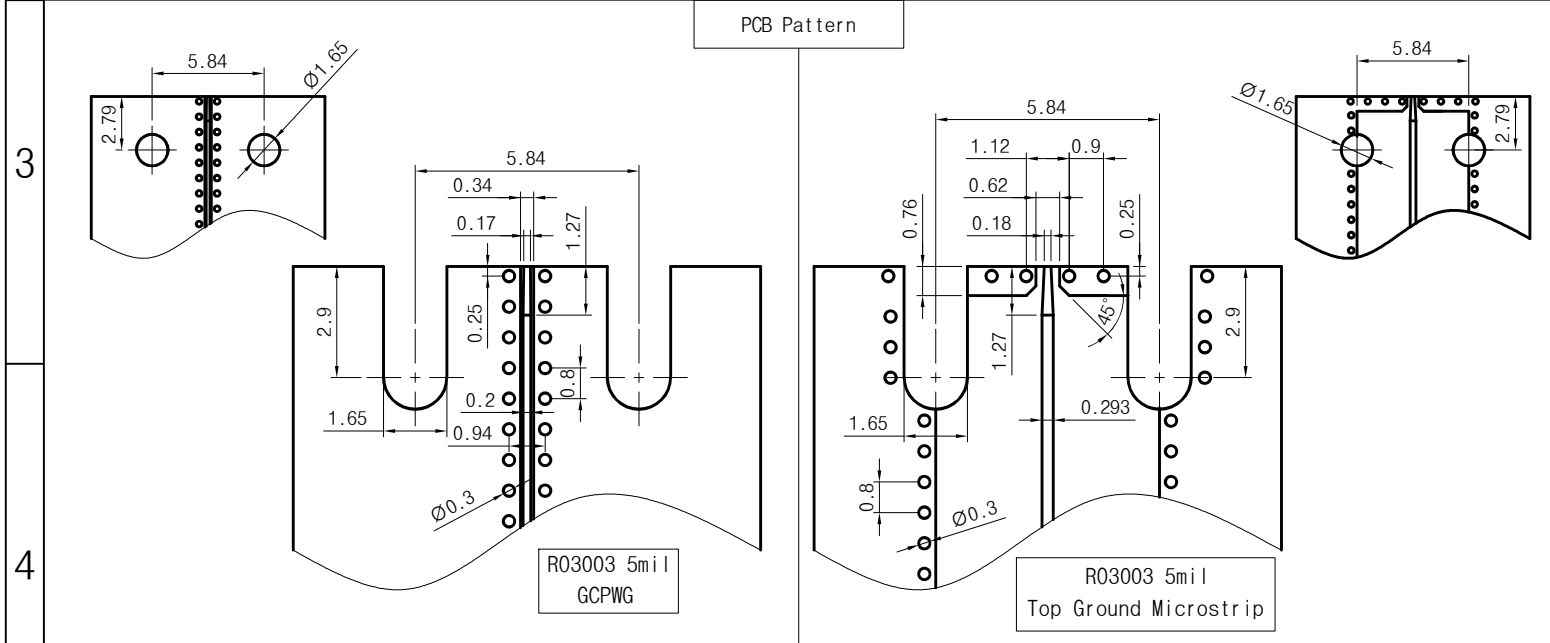
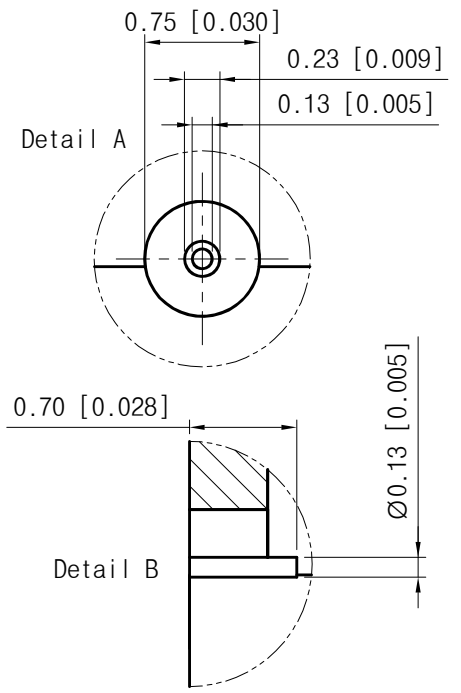

Revision			
Rev	Description	Drawn	Date
⚠	Added 4. Environmental	DJKim	20250418
Title		End Launch Narrow 1.0mm(F) Connector for Microstrip R03003 5mil(PCB)	
Part No.		NE00FS001	

THE INFORMATION HEREON/HEREIN IS PROPRIETARY TO WITH-WAVE CO., LTD. IT SHALL NOT BE COUPIED, DISCLOSED OR USED(PARTIALLY OR WHOLLY) IN ANY MANNER WITHOUT PRIOR EXPRESSED WRITTEN AUTHORIZATION OF WITH-WAVE CO., LTD.

Scale	N/A	Date	2020. 10. 19	Rev. A
Unit	mm[inch]	Drawn	Teri K	