

High Speed Connector 0.9mm Pitch Systems

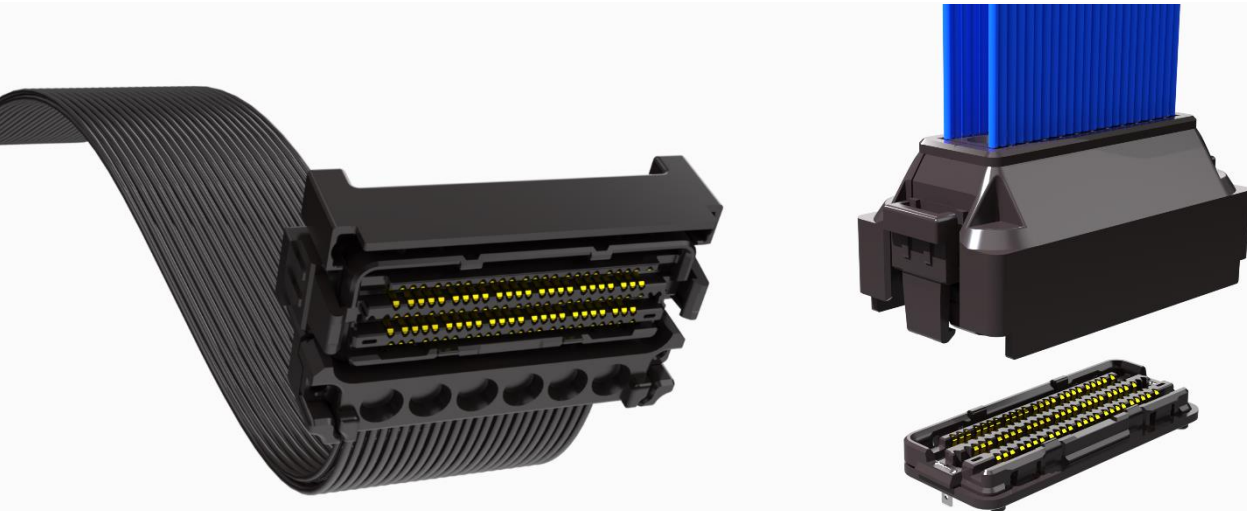

■ Features

- Higher bandwidth applications 28 Gbps NRZ, 56 Gbps PAM-4
- Stack heights from 5.0mm
- High pin counts : 120 total contacts(24 differential pairs)
- Low Loss Cable Port (Gray) : 5 differential pairs / RF Cable Port (Black) : 19 differential pairs
- Pitch 0.9 mm x 1.5mm
- Differential pair 92ohm nominal impedance
- Surface Mount BGA Pin Design

■ Benefits

- Minimizes impedance discontinuities
- Excellent Insertion and Return loss performance
- Low crosstalk noise and resonances
- Biggest forced-offset(Rigid alignment) tolerance
- Hermaphroditic mating interface
- Integrated power and additional signal pin per column

■ Application

- Telecommunication and Data Embedded
- Data Servers and Storage
- Industrial Controls and Equipment
- Medical Instrumentation
- Military Electronics
- Network Diagnostics
- Test and Measurement Electronics

High Speed Connector 0.9mm Pitch Systems

■ MECHANICAL PERFORMANCE

- Mating Tolerance :
 - X: $\pm 1.0\text{mm}$ (floating mating)
 - Y: $\pm 1.2\text{mm}$ (floating mating)
 - Z: $-0.2/+0.5\text{mm}$
- Forced-offset (Rigid alignment) tolerance : X/Y $\pm 0.2\text{mm}$
- Mating Force 0.45N max. per contact
- Un-mating Force 0.1N min. per contact

■ ELECTRICAL PERFORMANCE

- Contact Resistance: $<10\text{m}\Omega$ change from initial reading after environmental exposure
- Current Rating(with $<30^\circ\text{C}$ temperature rise above ambient): 0.5A min
- Insulation Resistance : 1000Mohm min
- Withstanding Voltage : 500Vrms min

■ MATERIAL

- Housing : High-Temperature LCP, UL94V-01
- Contacts : High performance Copper Alloy
- Plating(s) :
 - Contact Area 0.1 μm Gold(Au)
 - Nickel(Ni) Overall

■ ENVIRONMENTAL

- Operating Temperature range : -55 to $+85^\circ\text{C}$

High Speed Connector

High Density open pin filed arrays

withwave

Versatile RF & MW Test Solutions

CONNECTOR DRAWING

Part No. : HSB02L_M120S01H050A

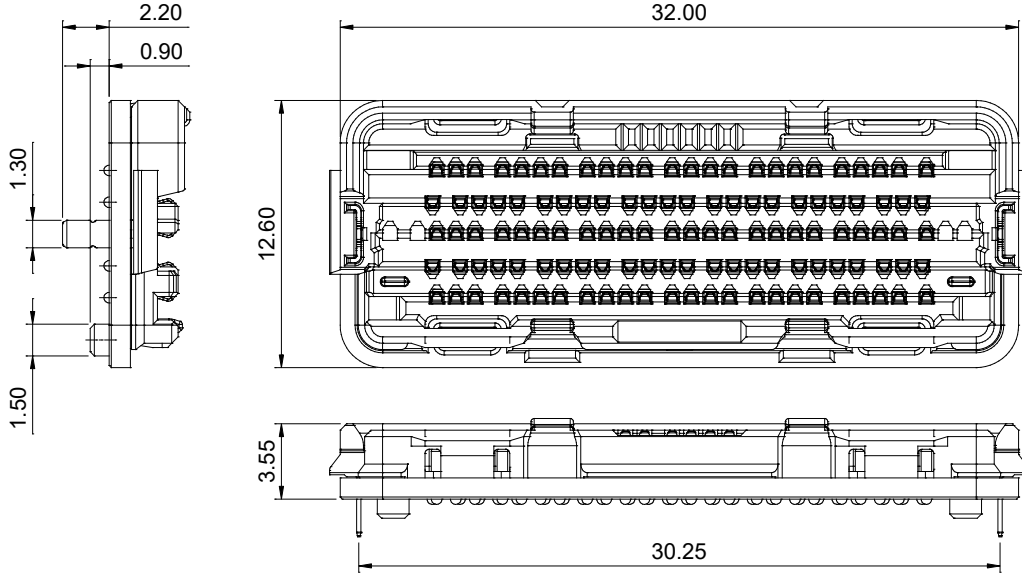

CABLE ASSEMBLY DRAWING

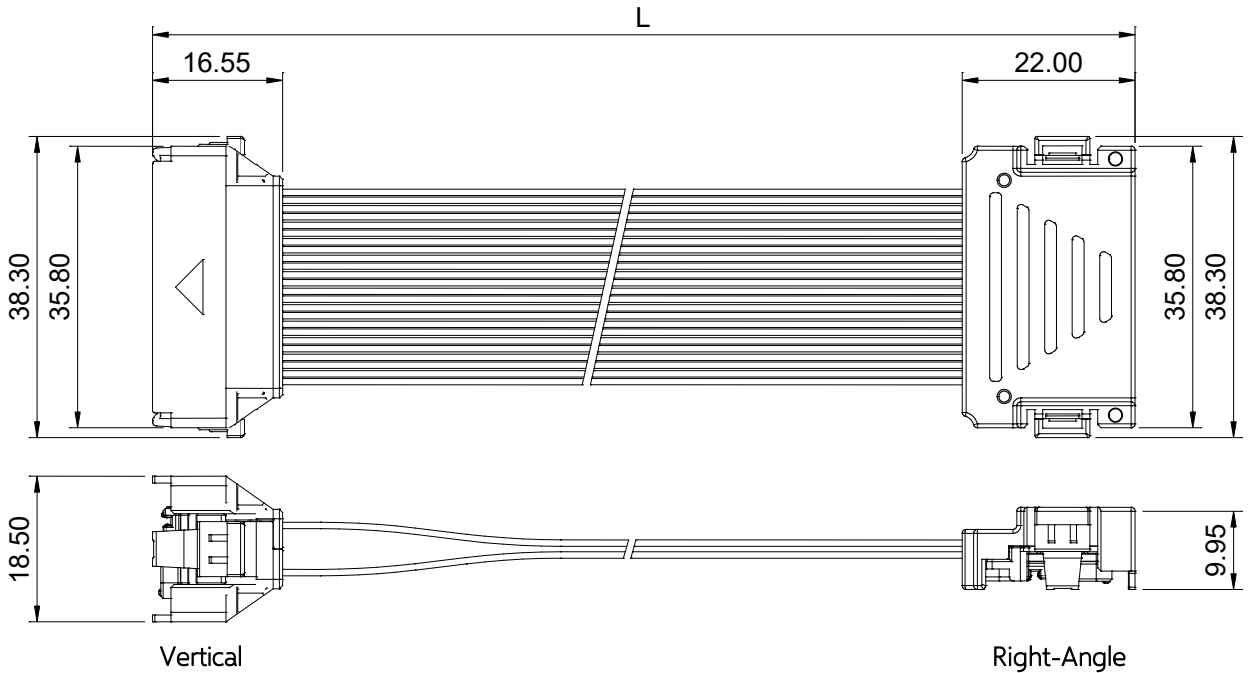

Part No.	L	Cable	+	Conn. 01 Vertical	+	Conn.02 Right Angle	Tolerance (%)
HSW00R01 – L030 – HSW00S02	320	300		3.05		16.95	3.2
HSW00R01 – L040 – HSW00S02	420	400		3.05		16.95	4.2

RECOMMENDED PCB LAYOUT (Board Connector)

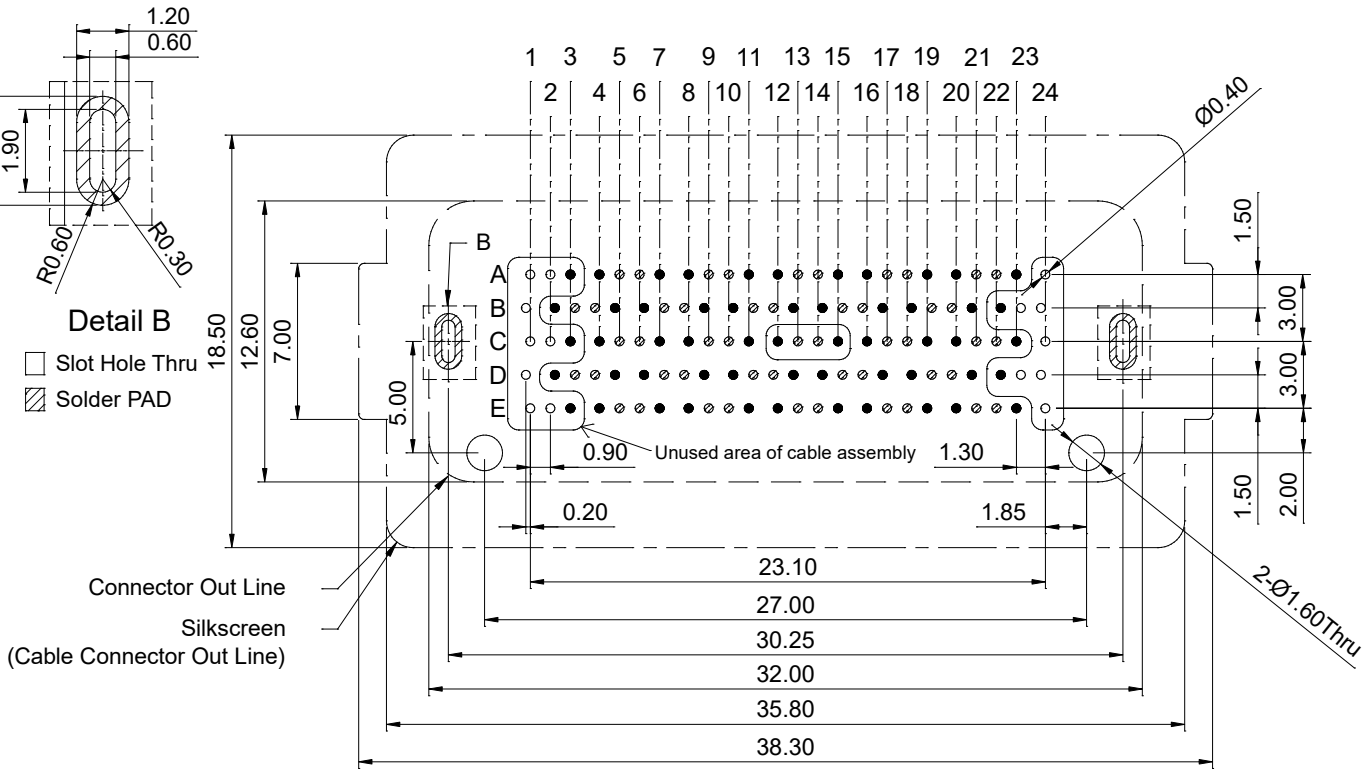

PIN MAP (MAIN BOARD-MATING BOARD)						
A1-E1	A2-E2	A3-E3	...	A22-E22	A23-E23	A24-E24
B1-D1	B2-D2	B3-D3	...	B22-D22	B23-D23	B24-D24
C1-C1	C2-C2	C3-C3	...	C22-C22	C23-C23	C24-C24
D1-B1	D2-B2	D3-B3	...	D22-B22	D23-B23	D24-B24
E1-A1	E2-A2	E3-A3	...	E22-A22	E23-A23	E24-A24

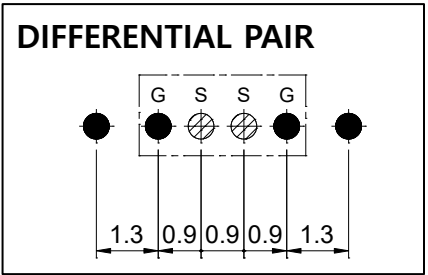

RECOMMENDED SOLDER MASK (Thickness 0.1T)

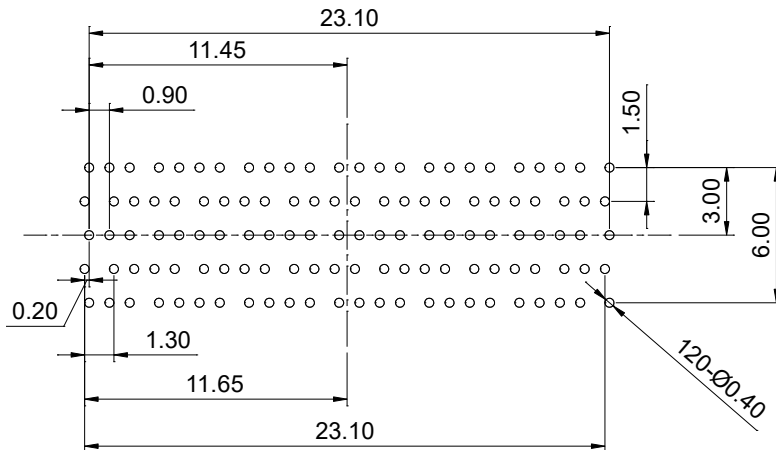

High Speed Connector

High Density open pin filed arrays

withwave

Versatile RF & MW Test Solutions

■ CABLE ASSEMBLY PIN MAP

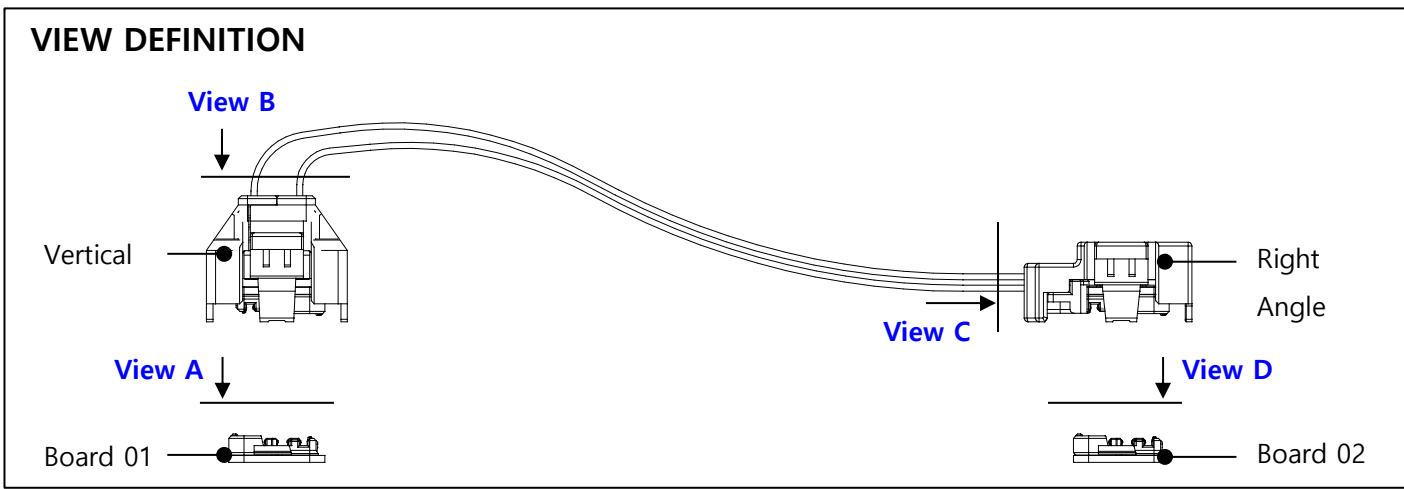
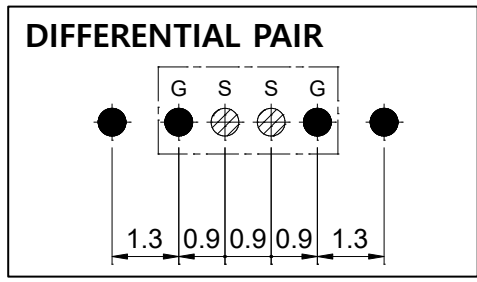
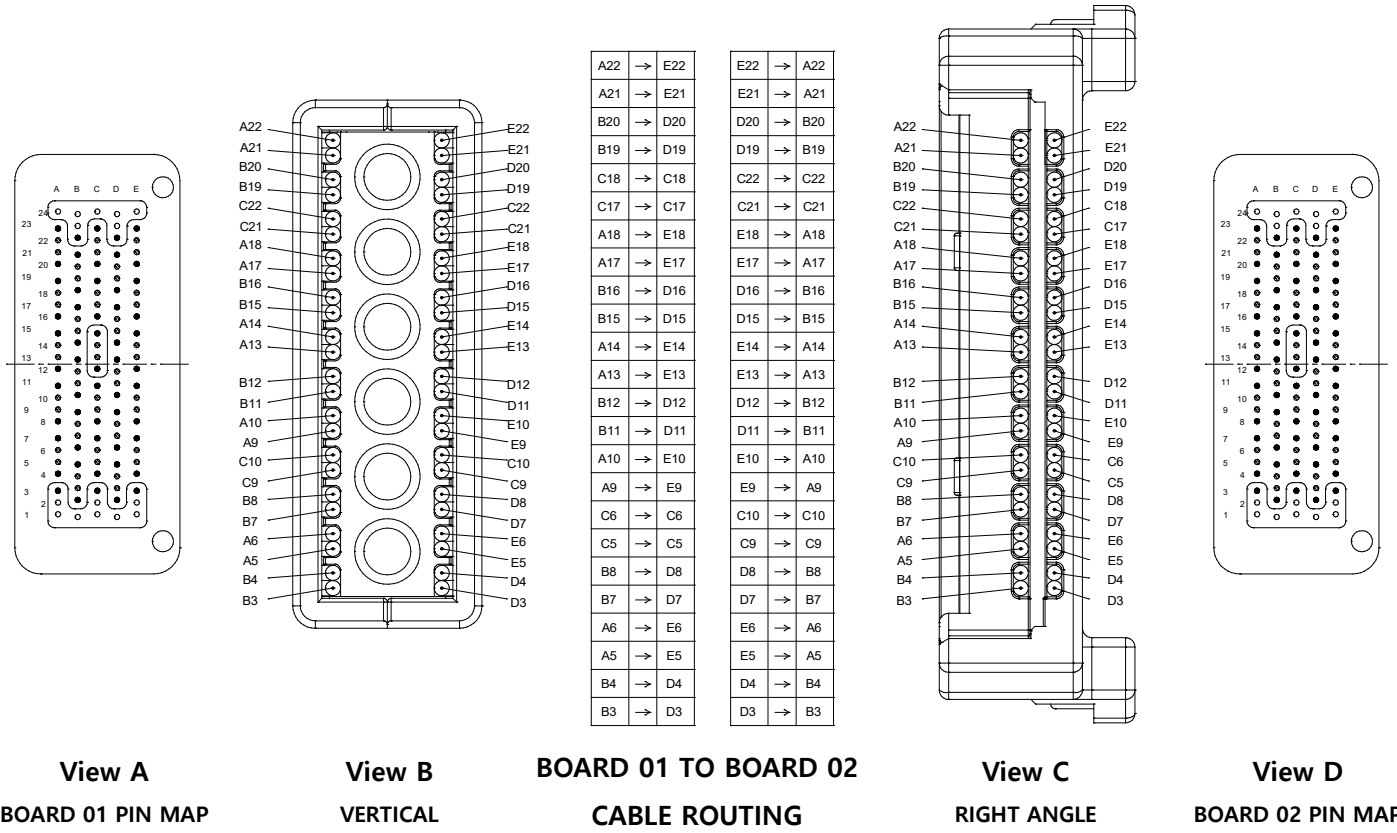

Connector & Cable assembly PIN MAP

BOARD 01
Layout
(Top View)

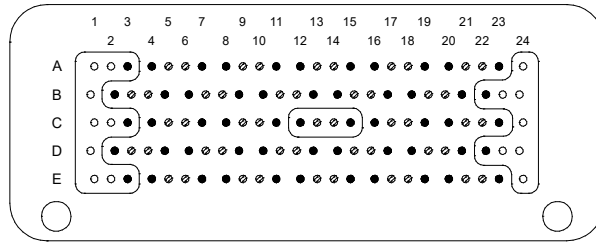

Cable Assembly 01
Vertical

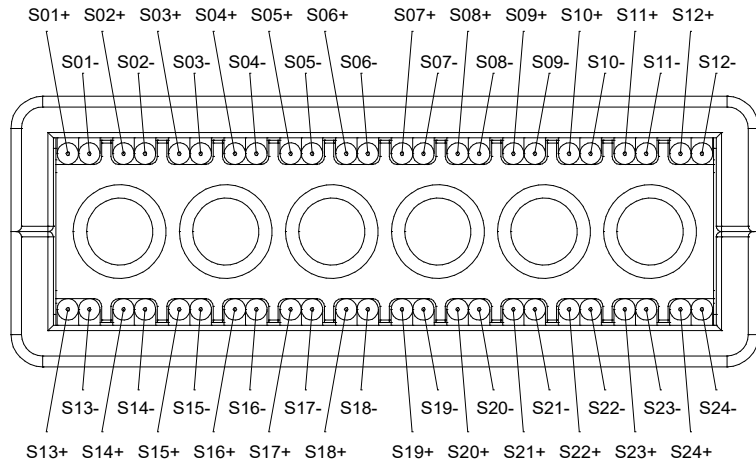

Cable Assembly 02
Right Angle

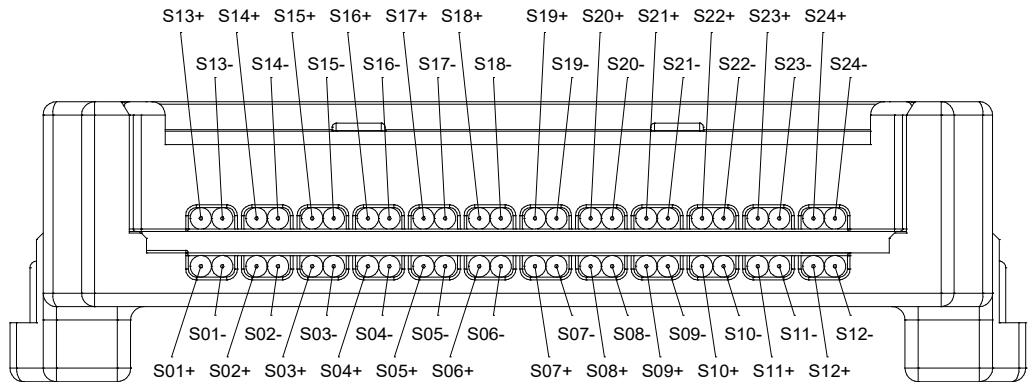

BOARD 02
Layout
(Top View)

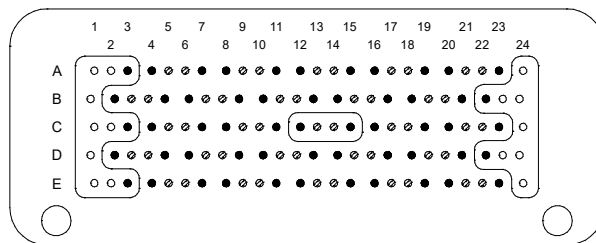

Connector Part Number

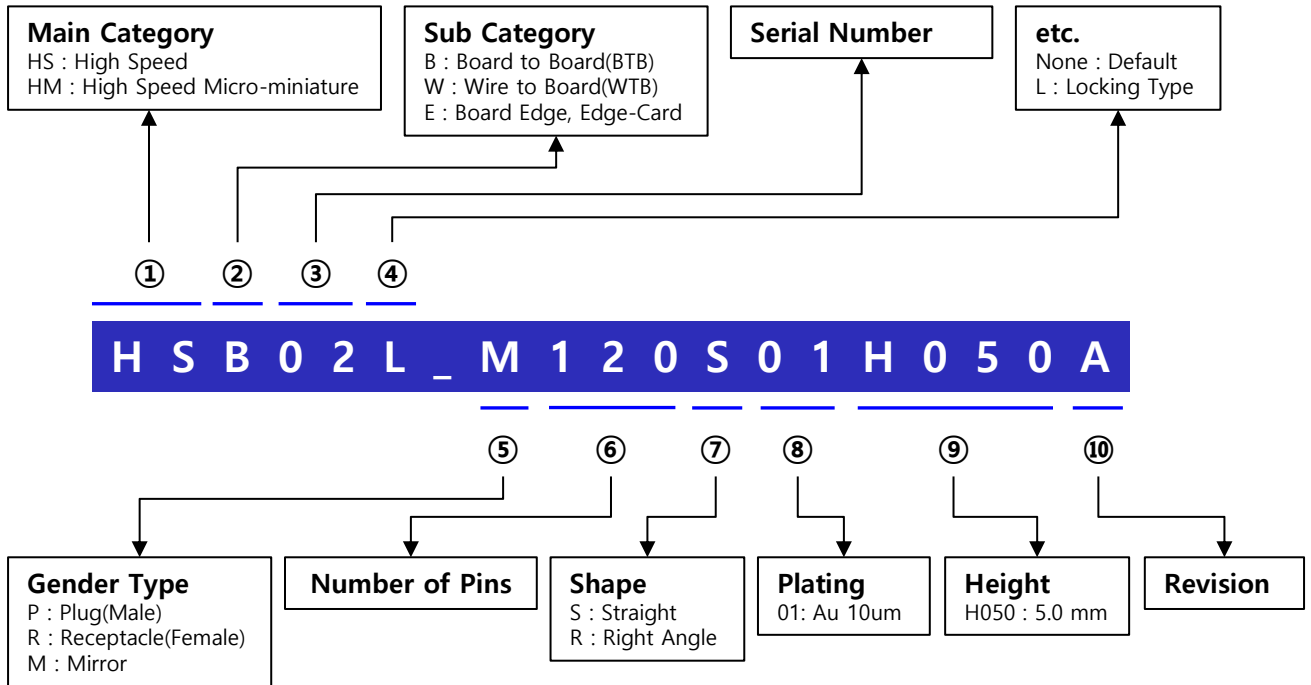

Cable Assembly Part Number

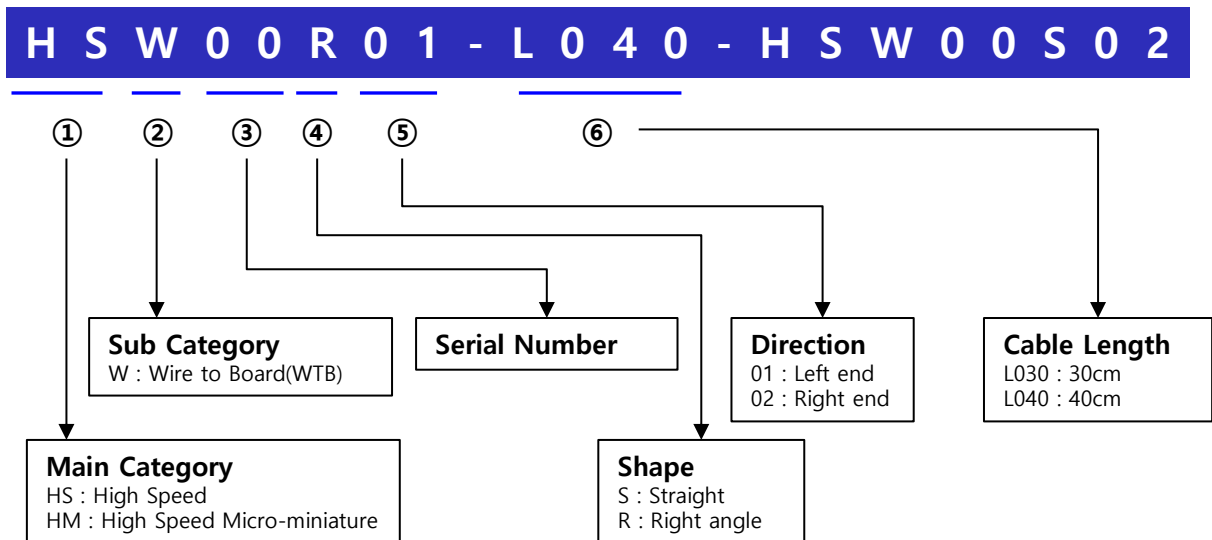

RF CABLE STRUCTURE

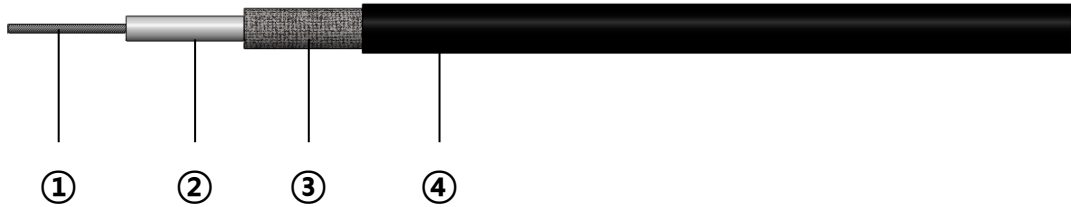

	Structure	Material	Standard value
①	Inner conductor	SCW (Stranded)	0.15 (7/0.05)
②	Insulator	FEP	0.41
③	Outer conductor	SCW	0.60 (8/5/0.05)
④	Jacket	PEP (Black)	0.81

LOWLOSS CABLE STRUCTURE

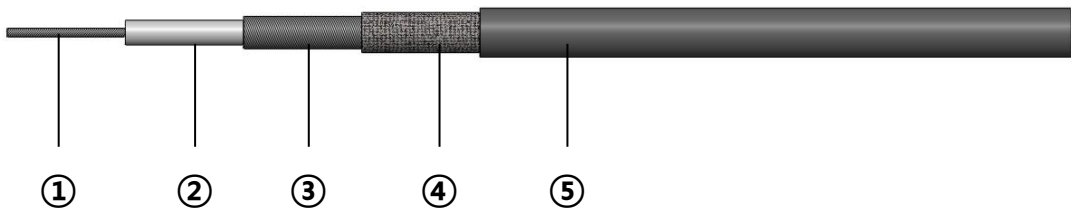

	Structure	Material	Standard value
①	Inner conductor	SCW (Stranded)	0.18 (7/0.06)
②	Insulator	FEP	0.51
③	Outer conductor 1	Cu tape	0.55 (0.012 x0.17)
④	Outer conductor 2	Tinned alloy wire	0.68 (16/5/0.03)
⑤	Jacket	PFA (Gray)	0.83